

D SERIES

DIMMING CONTROL PANEL

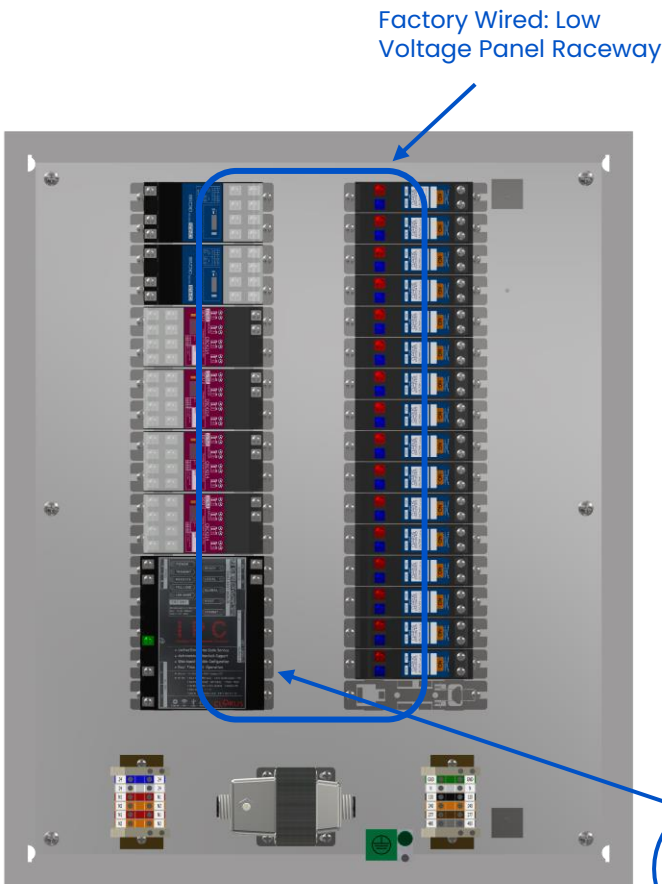

NXL-D16i Shown

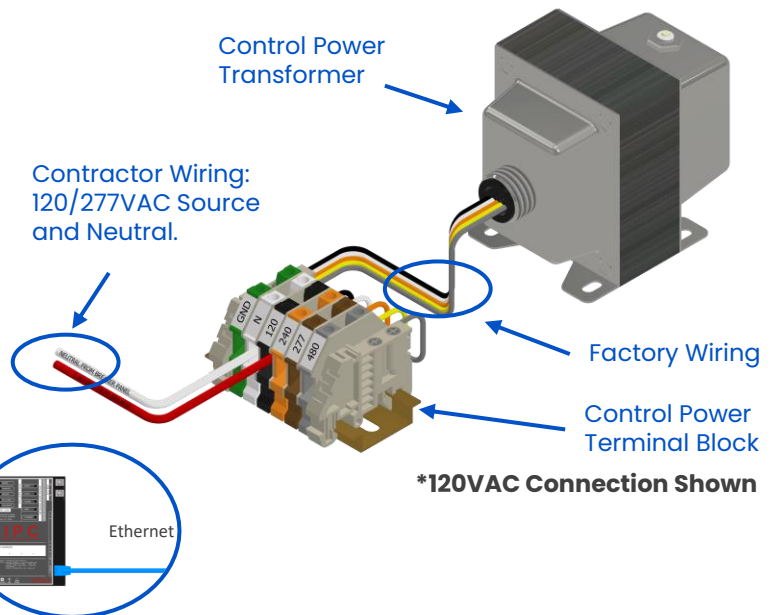
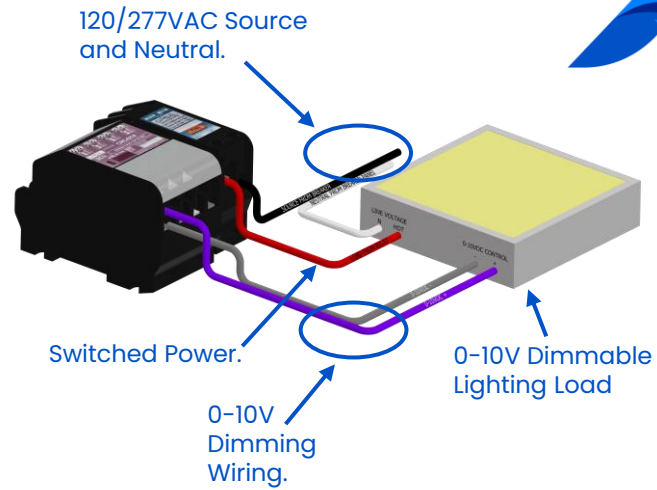

APPLICATION OVERVIEW

The D Series Panels are stand-alone 0-10V dimming panels that serve as the primary point of connection in the 2-Wire NexLight Lighting Control System. Utilizing the CRC1201, the R Series panels provide a Graphic User Interface for monitoring and control of all addresses on your lighting control system. Networking multiple (up to 250) standard panels (R Series and/or D Series) is easily done through a standard Ethernet (CAT5E or greater) Local Area Network. This networking approach allows for a truly segmented network design, while retaining the advantage of leveraging the reliability and simplicity of the NexLight 2-Wire Data Bus.

APPLICATION HIGHLIGHTS

- Networkable via Ethernet.
- Programming, Monitoring and Remote Override available through Graphic User Interface (GUI).
- Utilizes the CRC7000 Mechanically Latching Relay backed by NexLight's 20-Year Relay Warranty.
- 100 mA of Sinking Current per Dimming Channel.

TYPICAL RISER

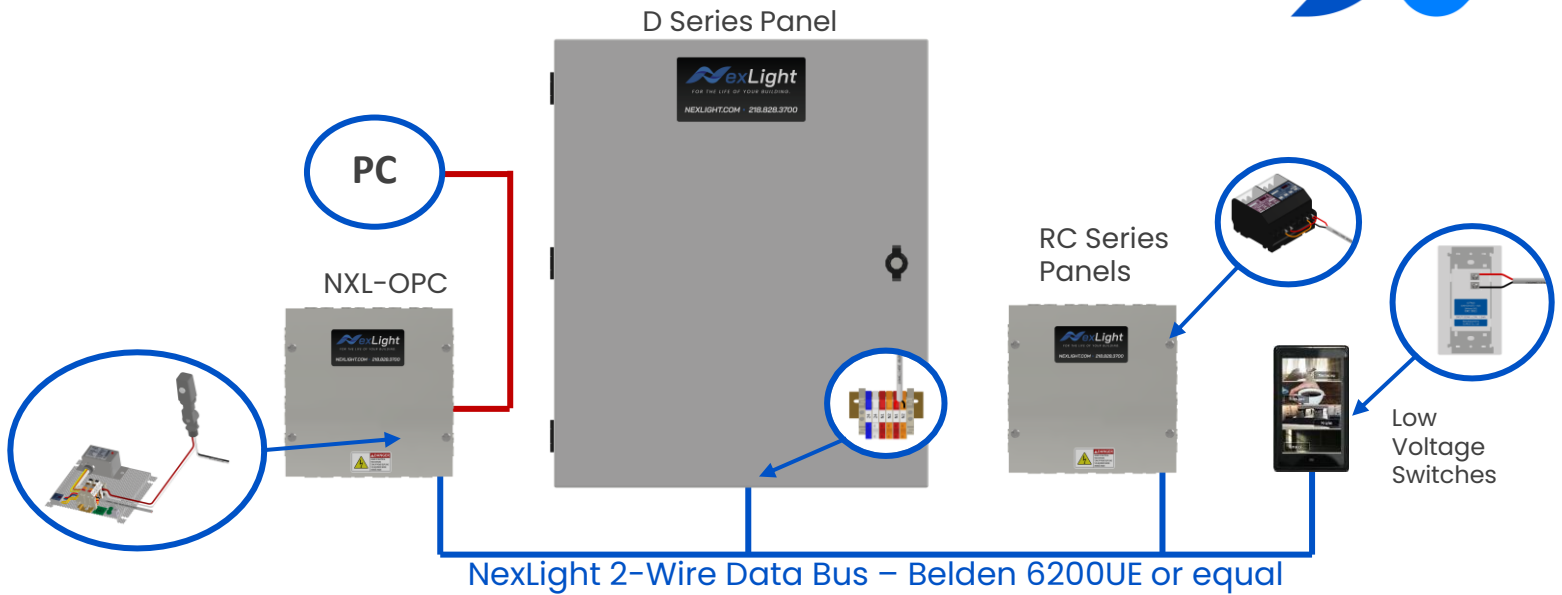

PANEL SCHEDULE

Record the control circuit wired to the terminal block

Information supplied by building IT Department

PANEL NAME:		IP ADDRESS:					
MOUNTING LOCATION:		SUBNET MASK:					
TRANSFORMER FEED:		DEFAULT GATEWAY:					
PANEL TYPE: NXL-D16s		PANEL DIMENSIONS: 24.00"H x 20.00"W x 6.00"D					
LEFT SIDE				RIGHT SIDE			
LOAD DESCRIPTION	SOURCE	ADDRESS	DEVICE	DEVICE	ADDRESS	SOURCE	LOAD DESCRIPTION
CRC2180 RELAY CONTROLLER				CRC7000	0-1		
				CRC7000	0-2		
CRC2180 RELAY CONTROLLER				CRC7000	0-3		
				CRC7000	0-4		
	CHANNEL 1	4	-1	CRC4214 0-10 DIMMER	CRC7000	1-1	
	CHANNEL 2		-2		CRC7000	1-2	
	CHANNEL 3		-3				
	CHANNEL 4		-4				

Record the Lighting Load Description

Record the Lighting Load Description

Record the source circuit breaker

STEPS TO INSTALLATION

1. Mount the D Series Panel in the desired location.
2. Wire the CRC7000 Relay to the Source and Lighting Load.
 - Record the Source and Lighting Load Description on the part number specific Panel Schedule.
3. Wire the CRC4214 0-10V Dimming Channel to the Lighting Load.
 - Record the Lighting Load Description on the part number specific Panel Schedule.
4. Connect Line Voltage to the Control Power Terminal Blocks.
 - Record the circuit breaker designation in the appropriate field at the top of the Panel Schedule.
5. Proceed with wiring the NexLight 2-Wire Data Bus; Reference the Table of Contents for specific applications.