



# CEILING MOUNT OCCUPANCY SENSOR

LOW VOLTAGE

## OVERVIEW

The **NexLight** family of ceiling mount occupancy sensors provides a range of control solutions for spaces with finished ceilings (e.g., tiles, sheetrock, and plaster). Preferred by contractors for their simple, yet flexible, mounting methods, **NexLight** sensors reduce installation time and fuss. **NexLight** products utilize the latest passive infrared technology and digital signal processing techniques to provide unmatched detection performance. Additionally, **NexLight** units are available with an integrated microphone to provide overlapping passive acoustic occupancy detection for rooms with obstructions or where occupant motion will be limited. Enhanced options for this sensor family include a photocell that will override lights off if sufficient ambient light is present, active daylight harvesting for 0-10V lighting, and an isolated relay for interfacing external systems (e.g., HVAC/BAS).

## BASIC OPERATION

Sensors detect movement in the infrared energy that radiates from occupants as they move within the devices field-of-view. Once occupancy is identified, the sensor signals a connected power/relay pack to switch on the connected lighting. If equipped with passive dual technology (PIR/Acoustic), the unit's microphone is then also enabled to further enhance detection while the lights are on. An internal timer is set to keep lights on during brief periods of inactivity, and is reset every time occupancy is signaled by either the passive infrared or acoustic detection technologies.

## APPLICATIONS

A single sensor can be used in small spaces like a private office, however, multiple low voltage sensors can be easily wired together to provide coverage for larger spaces like an open office.

- Classrooms
- Open Areas
- Conference Rooms
- Hallways
- Small Offices
- Copy Rooms
- Private Restrooms
- Break Rooms

## FEATURES

- **Digital Passive Infrared (PIR) Detection**
- **Passive Acoustic Detection (Optional)**
- **360° Coverage Patterns**
- **Compact Size and Matte Finish**
- **Four Contractor Friendly Mounting Methods**
- **Mounting Nipple Attachment with Integrated Hole Saw**
- **Convenient Test Mode and Adjustable Time Delays**
- **Optional Photocell, Daylight Harvesting, & Isolated Relay**

## SPECIFICATIONS

### ELECTRICAL

#### OPERATING VOLTAGE

12-24 VAC/VDC

#### CURRENT DRAW

5mA (PIR models)  
7mA (PIR w/ Photocell models)  
10mA (Dual Tech. models)  
12mA (Dual Tech. w/ Photocell models)

#### OUTPUT

Logic High VDC (Occupied Mode)

#### RECOMMENDED POWER PACK

PS-SWX-900 Series (**NEXLIGHT**)

#### DIMMING CAPACITY (-D OPTION)

50mA

#### DIMMING COMPATIBILITY

0-10 VDC Ballasts or Drivers  
Compliant with IEC 60929 Annex E.2

#### ISOLATED RELAY RATING

1A @ 30 VDC/VAC

### ENVIRONMENTAL

#### OPERATING TEMP

32°F to 122°F (0°C to 50°C) - Standard  
-40° F/C (with **-HE** Option)

#### RELATIVE HUMIDITY

0-95% Non-Condensing,  
Indoor Use Only

### PHYSICAL

#### SIZE

4.00" Diameter x 1.25" H  
(10.16 x 3.17 cm)

#### WEIGHT

4.75 oz

#### COLOR

White or Black

### OPERATION

#### TIME DELAYS

30 sec to 30 min (typical)  
10 minute default  
5 sec test mode

### CODE COMPLIANCE

Sensors can be used to meet  
ASHRAE 90.1, IECC, & Title 24  
energy code requirements



# ORDERING INFO

SAMPLE MODEL # PS-SWX-222-1

	PRODUCT	DETECTION	COVERAGE	VOLTAGE	OPTIONS					
PS-SWX-	Ceiling Mount Sensor	2	Passive Infrared (PIR)	0	Small Motion 360°	1	Low Voltage	- 1	Daylight Harvesting (0-10V)	- D <sup>2</sup>
			Passive Infrared (PIR) + Photocell	1	Large Motion 360°	2			Isolated Auxiliary Relay	- AR
			Passive Dual Technology (PIR/Acoustic)	2	High Bay 360°	3 <sup>1</sup>			High Humidity Environment	- HE
			Passive Dual Technology (PIR/Acoustic) + Photocell	3					Black Cover Lid & Lens	- BK <sup>3</sup>

## ACCESSORIES

**PS-SWX-299-JP** - Ceiling Sensor Trim Ring for Mounting to Single Gang Mudring, Handy Box, or 4" Octagon Box

**Note 1:** Not available on Dual Tech. units

**Note 2:** Only available on units w/ Photocells

**Note 3:** Units w/ Photocells will have standard white lenses

# COVERAGE

## PASSIVE INFRARED (PIR)

- 8 to 15 ft (2.44 to 4.57 m) mounting height recommended for small and large motion lenses. For 15 to 40 ft (2.44 to 12.20 m) mounting heights use high bay lens.
- Detection range improves when walking across beams as compared to into beams
- Lenses can be swapped in field if necessary, contact technical support for assistance

### SMALL MOTION 360°

- Best choice for detection of small motions from sitting occupants (e.g., hand motion)
- ~500 ft<sup>2</sup> of coverage

### LARGE MOTION 360°

- Best choice for detection of larger motion (e.g., walking)
- ~2000 ft<sup>2</sup> of coverage
- One of the longer segments of the coverage pattern aligns with the screw hole axis on the sensor (shown as dotted line on Top View diagram below)

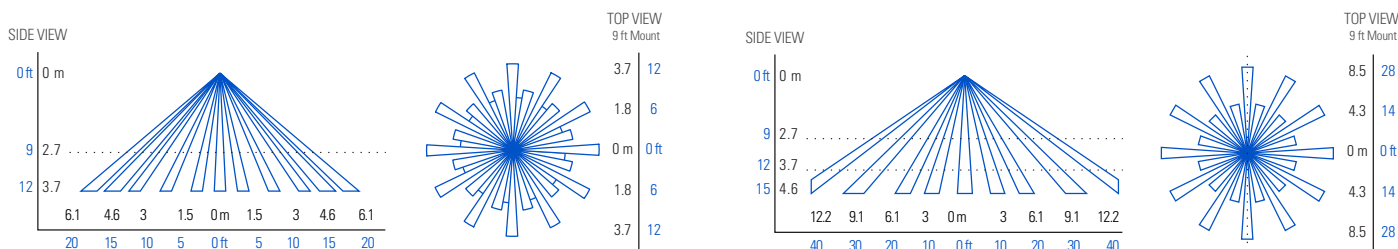

### HIGH BAY 360°

- Best choice for mounting heights above 15ft
- Recommended for gyms, warehouses, and other high ceiling areas where multiple sensor coverage is required
- Not recommended for areas where occupants are sitting
- Gaps between outer segments get larger as mounting height increases
- Not available with acoustic (dual technology)

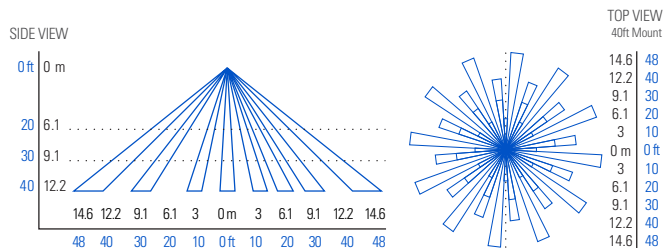

## DUAL TECHNOLOGY (PIR/ACOUSTIC)

- Units with dual technology (PS-SWX-221-1 and PS-SWX-222-1) have overlapping acoustic detection of the complete PIR coverage area
- A PIR event is required to initially enable acoustic detection
- Sounds indicating occupancy reset the sensor's time delay while non-occupant noises are filtered out
- Occupant sounds alone will not keep lights on indefinitely, PIR motion must be periodically detected for lights to remain on for an extended time
- After sensor time out expires, acoustic detection remains enabled for 15 seconds to enable voice reactivation of lights for additional convenience and safety

# DAYLIGHT HARVESTING & PHOTOCELL OPERATION

Units with the integrated photocell option can provide on/off or inhibit only control of lighting. Units with the daylight harvesting option can also directly dim 0-10V lighting.

### DAYLIGHT HARVESTING

- Lights will gradually dim in order to maximize energy savings while maintaining desired overall lighting level.
- Recommend for spaces where it is important to not distract occupants (e.g., offices, classrooms).
- Option to dim to low trim or turn lighting off.

### ON/OFF PHOTOCELL CONTROL

- Lights are switched off if ambient light level surpasses threshold and back on if level drops.
- Recommended for public spaces (hallways, entryways, etc) where fully switching of lighting off and on will not cause distraction of occupants.

### INHIBIT ONLY PHOTOCELL CONTROL

- Lighting is held off if sufficient ambient light level is present upon initial occupancy.
- Lighting will turn on if light level drops below setpoint.
- Once on, lighting will only turn off from vacancy or a manual switch, never from daylight.

# WIRING

## STANDARD WIRING

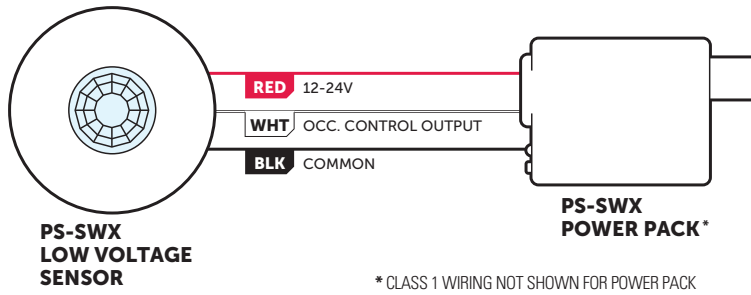

## OCCUPANCY + DAYLIGHT HARVESTING

- Lights will gradually dim in order to maximize energy savings while maintaining desired overall lighting level.
- Lights will dim only to low trim if white wire is connected to power pack. Connect blue wire to power pack to switch lighting completely off from daylight.

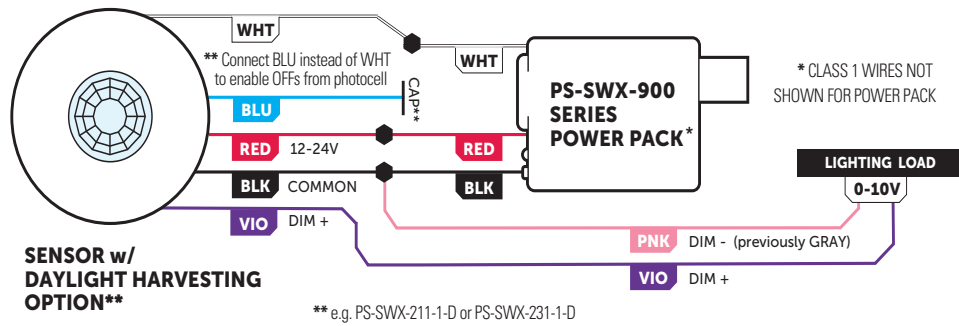

## SEPARATE OCCUPANCY ZONE & OCCUPANCY + ON/OFF PHOTOCELL ZONE

- During occupied state, photocell output (blue wire) will turn lights off if ambient light level surpasses threshold and back on if level drops.
- Also configurable to prevent lights from initially turning on, but not to turn them off once lights are on (i.e. Inhibit Only operation).

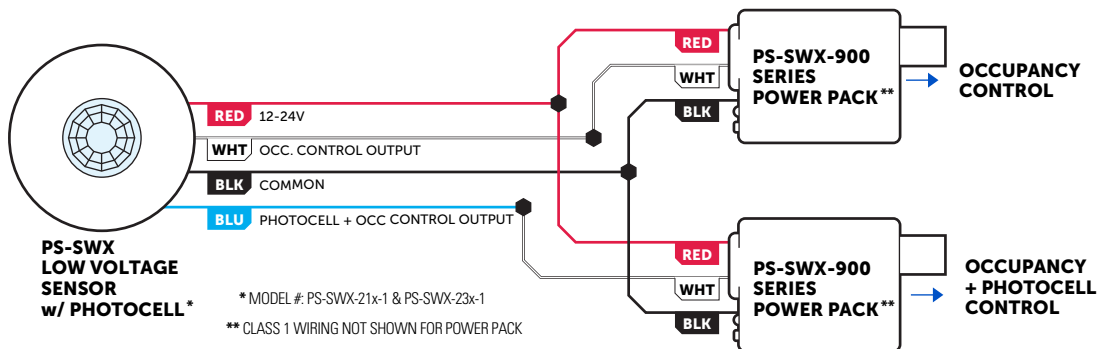

# WIRING CONT.

## SENSOR INTERFACE TO BMS

- The auxiliary output relay (model option -AR) is designed to interface with many types of BMS, VAV units, and relay panels
- Operation of relay (brown wires) is configurable:
  - By default the relay latches closed when occupancy is detected (white wire goes high)
  - Relay can be configured to alternatively follow the occupancy + photocell (blue wire) output
  - Relay polarity (open vs closed) can also be reversed

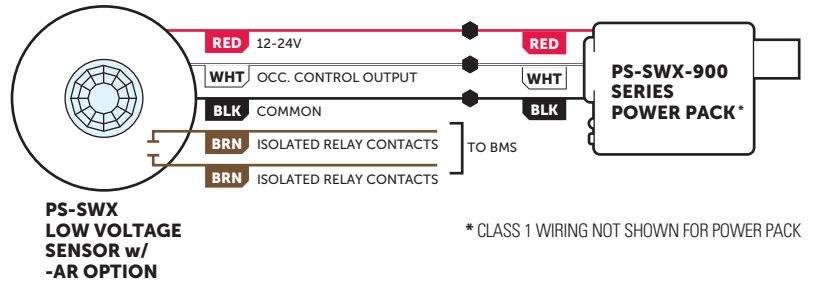

# INSTALLATION OPTIONS

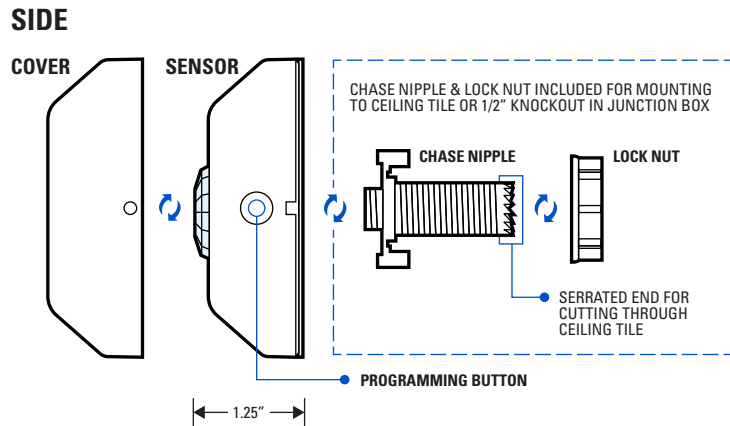
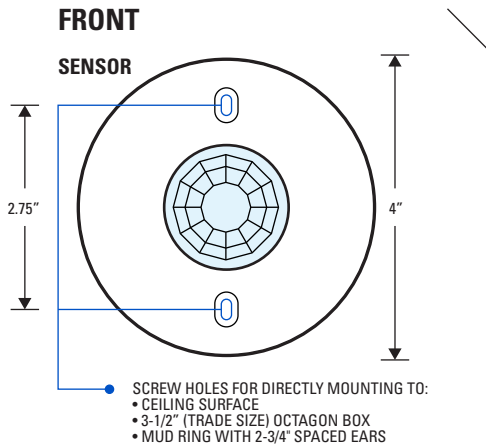

**Note:** If mounting to a Single Gang Mudring, Handy Box, or 4" Octagon Box, a trim ring is required. Part Number: **PS-SWX-299-JP**.

## ADDITIONAL MOUNTING OPTIONS USING PS-SWX-299-JP TRIM RING

