



# WIDE VIEW & HALLWAY OCCUPANCY SENSOR

LOW VOLTAGE

## OVERVIEW

**NexLight** wide view and hallway occupancy sensors enable mounting to a wall, corner, junction box, or conduit. This flexibility reduces contractor installation time and provides a secure and clean finished appearance. **NexLight** products utilize the latest passive infrared technology and digital signal processing techniques to provide unmatched detection performance. Additionally, these **NexLight** units are available with an integrated microphone to provide overlapping passive acoustic occupancy detection for rooms with obstructions or where occupant motion will be limited.

## BASIC OPERATION

Sensors detect movement in the infrared energy that radiates from occupants as they move within the devices field-of-view. Once occupancy is identified the sensor signals a connected power/relay pack to switch on the connected lighting. If equipped with passive dual (PIR/Acoustic) technology, the unit's microphone is then also enabled to further enhance detection while the lights are on. An internal timer is set to keep lights on during brief periods of inactivity, and is reset every time occupancy is signaled by either the passive infrared or acoustic detection technologies. Additionally, optional daylight detection is available that will turn off controlled lighting whenever there is sufficient ambient light in the space.

## APPLICATIONS

A single sensor may provide sufficient coverage in many spaces, however, multiple low voltage sensors can be easily wired together to provide improved coverage for large or irregular shaped spaces.

- Classrooms
- Large Offices
- Hallways/Corridors
- Open Areas
- Conference Rooms

## FEATURES

- **Digital Passive Infrared (PIR) Detection**
- **Passive Acoustic Detection (Optional)**
- **Wide View (120°) or Hallway (Long Range) Coverage Pattern Options**
- **Compact Size and Matte Finish**
- **Five Contractor Friendly Mounting Methods**
- **Mounting Nipple Attachment with Integrated Hole Saw**
- **Convenient Test Mode and Adjustable Time Delays**
- **Optional Ambient Light Override (Photocell)**

## SPECIFICATIONS

### ELECTRICAL

**OPERATING VOLTAGE**  
12-24 VAC/VDC

**CURRENT DRAW**  
5mA (PIR models)  
7mA (PIR w/ Photocell models)  
10mA (Dual Tech. models)  
12mA (Dual Tech. w/ Photocell models)

**OUTPUT**  
Logic High VDC (Occupied Mode)

**RECOMMENDED POWER PACKS**  
**NEXLIGHT** (e.g., PS-SWX-900)

**ISOLATED RELAY RATING**  
1A @ 30 VDC/VAC

### ENVIRONMENTAL

**OPERATING TEMP**  
32°F to 122°F (0°C to 50°C) - Standard  
-40° F/C (with **-HE** option)

**RELATIVE HUMIDITY**  
0-95% Non-Condensing,  
Indoor Use Only

**ROHS COMPLIANT**

### PHYSICAL

**SIZE**  
2.875" H x 2.75" W x 3.25" D  
(7.30 x 6.98 x 8.25 cm)

**WEIGHT**  
4.75 oz.

**COLOR**  
White or Black

### OPERATION

**TIME DELAYS**  
30 sec. to 30 min. (Typical)  
10 Minute Default  
5 sec. Test Mode

### CODE COMPLIANCE

Sensors can be used to meet  
ASHRAE 90.1, IECC, & Title 24  
energy code requirements



# COVERAGE PATTERN

## PASSIVE INFRARED (PIR)

### WIDE VIEW 120°

- Small motion (e.g., hand movements) detection up to 40 ft (12.19 m)
- Large motion (e.g., walking) detection up to 70 ft (21.34 m)
- Designed for 8 to 12 ft (2.44 to 3.66 m) high mounting

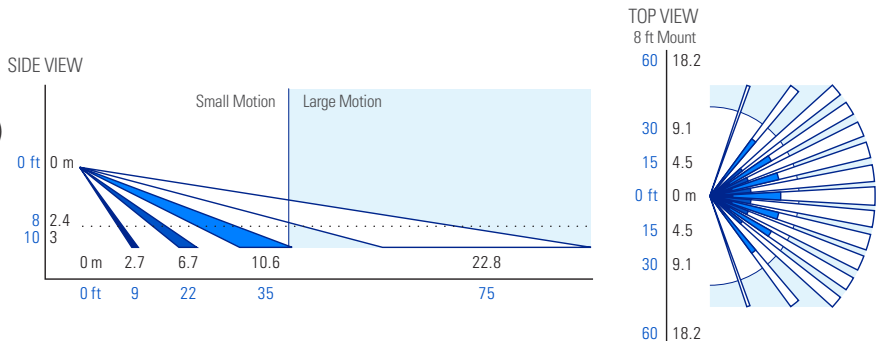
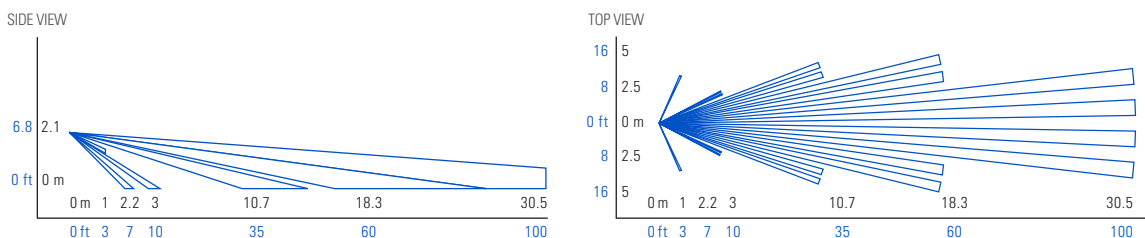

Diagram reflects sensor in first position. Adjust angle downward if mounting above 10 feet or to decrease gap directly under sensor.

### HALLWAY (LONG RANGE)

- Designed for 8 to 12 ft (2.44 to 3.66 m) high mounting
- Large motion (e.g., walking) detection up to 100 ft (30.48 m)
- Detection occurs sooner when crossing coverage beams upon entry to a hallway as opposed to entering from the end and walking directly at the sensor



## DUAL TECHNOLOGY (PIR/ACOUSTIC)

- Units with dual technology (PS-SWX-421-1 and PS-SWX-431-1) have overlapping acoustic detection of the complete PIR coverage area.
- A PIR event is required to initially enable acoustic detection
- Sounds indicating occupancy reset the sensor's time delay while non-occupant noises are filtered out
- Occupant sounds alone will not keep lights on indefinitely, PIR motion must be periodically detected for lights to remain on for an extended time
- After sensor time out expires, acoustic detection remains enabled for 10 seconds to enable voice reactivation of lights for additional convenience and safety
- Not available on units with Hallway (Long Range) lens

## AMBIENT LIGHT OVERRIDE (PHOTOCELL) OPERATION

Sensors with an integrated photocell will turn lights on/off depending on the amount of ambient light detected. This operation makes them ideal for lighting near skylights or windows.

# ORDERING INFO

SAMPLE MODEL # PS-SWX-421-1

	PRODUCT		DETECTION		COVERAGE		VOLTAGE		OPTIONS	
PS-SWX	Wide View Sensor	4	PIR	0	120° Wide View	1	Low Voltage	- 1	Isolated Auxiliary Relay	- AR
			PIR + Photocell	1	Hallway (Long Range)	2*			Humid Environment	- HE
			Dual Tech (PIR + Acoustic)	2*					Black Cover Lid & Lens	- BK <sup>1</sup>
			Dual Tech + Photocell (PIR + Acoustic + Photocell)	3*						

\* Dual Tech detection options not available for units with the Hallway coverage option.

**Note 1:** Not available on units w/ Photocells

# WIRING

## STANDARD WIRING

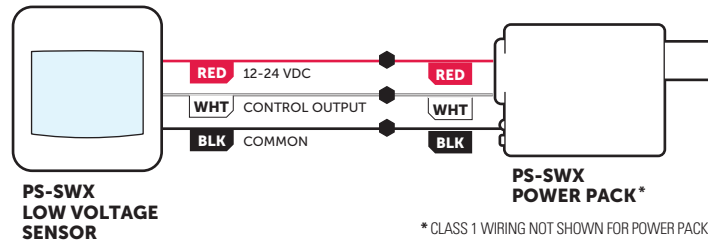

## SENSOR CONTROL OF SEPARATE OCCUPANCY & PHOTOCELL ZONES

- During occupied state, photocell output (blue wire) will turn lights off if ambient light level surpasses threshold and back on if level drops
- Also configurable to prevent lights from initially turning on, but not to turn them off once lights are on
- Configurable ambient light threshold levels or auto-selection

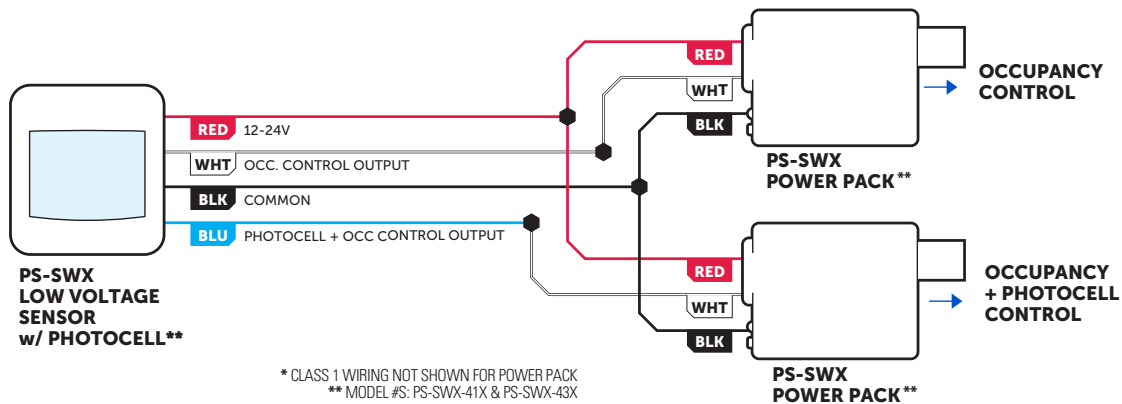

## SENSOR AUXILIARY RELAY INTERFACE TO BMS

- The auxiliary output relay (model option -AR) is designed to interface with many types of BMS, VAV units, and relay panels
- Operation of relay (brown wires) is configurable:
  - By default the relay latches closed when occupancy is detected (white wire goes high)
  - Relay can be configured to alternatively follow the occupancy + photocell (blue wire) output (if unit is equipped)
  - Relay polarity (open vs closed) can also be reversed

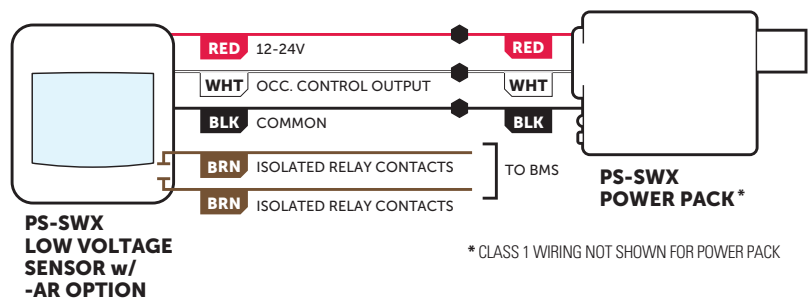

# INSTALLATION OPTIONS

## SENSOR & MOUNTING BRACKET

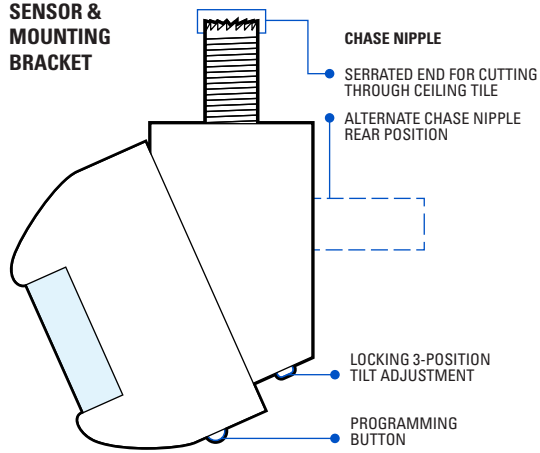

## REAR INSTALLATION

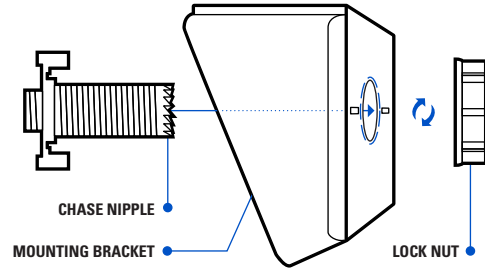

## MOUNTING WITH CHASE NIPPLE RECOMMENDED

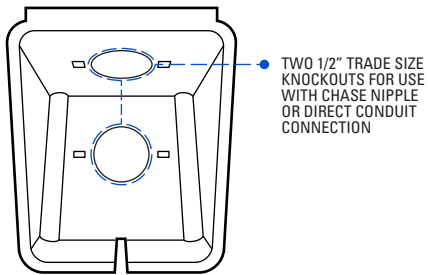

CHASE NIPPLE & LOCK NUT INCLUDED FOR MOUNTING TO CEILING TILE OR 1/2" KNOCKOUT IN JUNCTION BOX

## TOP INSTALLATION

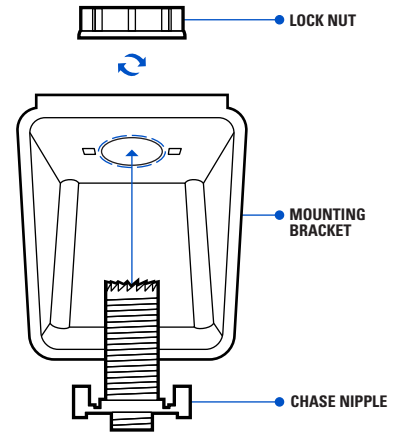

## ADDITIONAL MOUNTING METHODS

