



POWER PACK CONTROLLER

LINE VOLTAGE

OVERVIEW

NexLight power pack controllers transform incoming line voltage power to Class 2 low voltage as needed by sensors or other control devices. Additionally, they switch on/off power to the connected lighting load as directed by the sensors and controls. **NexLight** power packs utilize a powerful microprocessor to optimize its switching timing in order to ensure long relay life even when controlling high-inrush LEDs and ballast loads. As with all **NexLight** products, these power packs are easy to install and incorporate features which reduce contractor labor time. An elongated chase nipple with snaps for quick installation and an optional snap-on low voltage wire chamber make for a hassle free contractor experience. All **NexLight** products are proudly made in the USA.

BASIC OPERATION

An input signal indicating occupancy from one or more connected sensors will signal the pack's integrated relay to close. Once closed, line voltage will flow through the relay and turn on the connected lighting load. When the input signal indicates the occupied period has ended, the relay will open and lighting will switch off. This pack is also available with an auxiliary switch input to enable manual on, hold on, and hold off configurations. Partial off (e.g. auto off to 50%) and partial on (e.g., auto on to 50%) operation can also be achieved using the optional 0-10V stepped dimming output.

FEATURES

- Powers Low Voltage Sensors
- Switches Line Voltage Loads
- Electronically Timed Switching (i.e. Zero Crossing) Ensures Long Relay Life
- Integrated Test/Programming Button
- Plenum Rated (UL 2043)
- Optional Snap-On Attachment Provides Chamber for Low Voltage Wire Connections
- Optional Switch Input for Manual On, Hold On, or Hold Off Operation
- Optional 0-10V Stepped Dimming Output for Partial Off or Partial On Operation

SPECIFICATIONS

ELECTRICAL

OPERATING VOLTAGE

120/277 VAC

CLASS 2 RATINGS

Output capacity: 18 VDC, 150 mA
(PS-SWX-900 / PS-SWX-900-AX / PS-SWX-920)

Output power for connected devices:

80 mA (PS-SWX-900 / PS-SWX-900-AX)

150 mA (PS-SWX-920)

Power draw if not connected to

120/277 VAC: 70 mA

LOAD RATINGS (PS-SWX-900 / PS-SWX-900-AX / PS-SWX-910 only)
(relays use zero-cross switching)

20A @ 120 V -

General Purpose Plug Load

20A @ 120/277 VAC -

General Purpose, Tungsten

Magnetic Ballast

16A @ 120/277 VAC -

Electronic Ballast, LED Driver

DC LOAD RATINGS

20A @ 28 VDC (MAX)

1A @ 5 VDC (MIN)

DIMMING LOAD

(Models with -D2 option only)

50mA, (0-10 VDC ballasts or drivers compliant with IEC 60929 Annex E.2)

MOTOR LOAD

1 HP



ENVIRONMENTAL

OPERATING TEMP

32°F to 122°F (0°C to 50°C) Std.

-40° F/C (with -HE Option)

RELATIVE HUMIDITY

0-95% Non-Condensing, Indoor Use Only

ROHS COMPLIANT

PHYSICAL

SIZE & WEIGHT

3.00" H x 2.25" W x 1.88" D
(7.62 cm x 5.72 cm x 4.78 cm)

6.00 oz.

COLOR

Blue

MOUNTING

1/2" Knockout

RELAY TEST BUTTON

LED STATUS INDICATOR

Bi-color White & Blue



ORDERING INFO

SAMPLE MODEL # PS-SWX-900-AX

	PRODUCT	FUNCTIONALITY	VOLTAGE	AUX SWITCH INPUT	ADDITIONAL OPTIONS
PS-SWX	Power Pack	9	0	Blank	Partial Off / On Control* (Stepped Dimming (0-10V) High Humidity Environment Auxiliary Contact Closure Relay**
		Single Relay + 150 mA Supply	120/277 V	None	-D2-HL*
		Secondary Relay	0	Auxiliary Switch Input	-HE
		150 mA Supply	2		-AR**

*Requires -AX option

**Available with PS-SWX-910 only

ACCESSORY	DESCRIPTION
PS-SWX-999	Snap-On Low Voltage Wiring Chamber

WIRING

BASIC SENSOR WIRING

MODEL #: PS-SWX-900

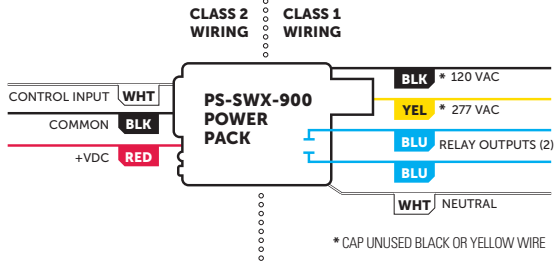

MODEL #: PS-SWX-900-AX-D2-HL

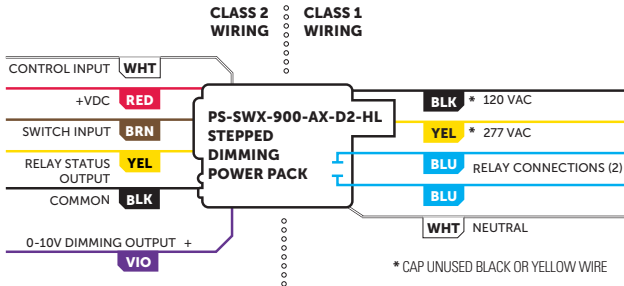

MODEL #: PS-SWX-900-AX

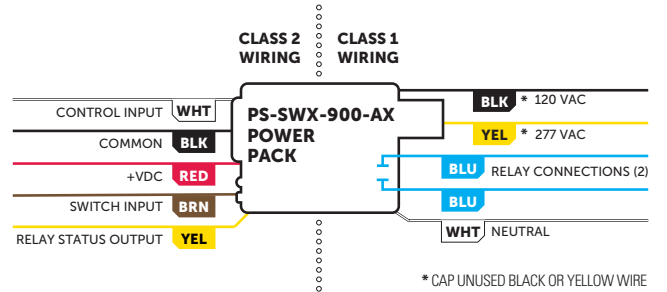

MODEL #: PS-SWX-910

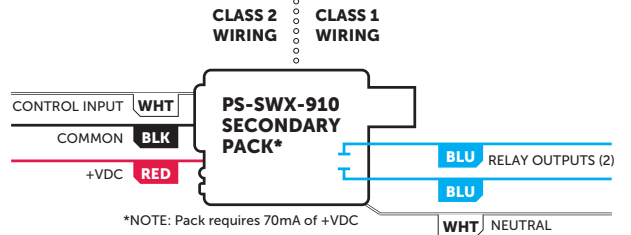

MODEL #: PS-SWX-910-AR

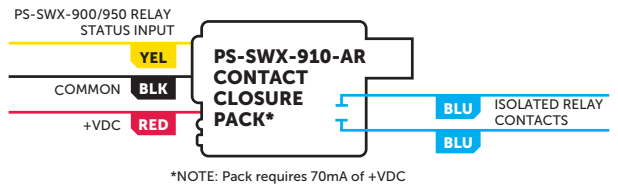

COMMON WIRING CONFIGURATIONS

SINGLE SENSOR

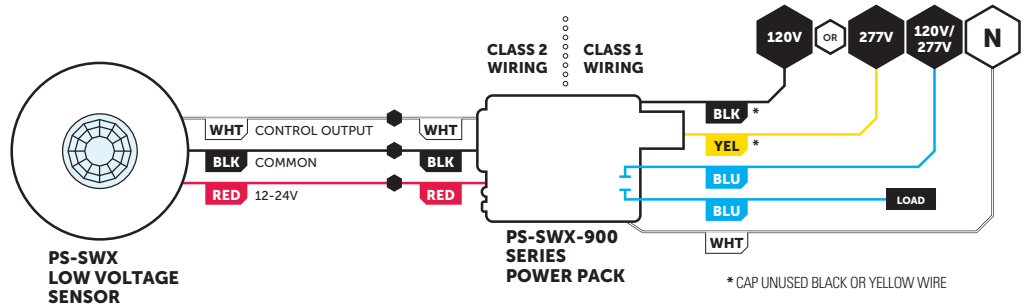

MULTIPLE SENSOR

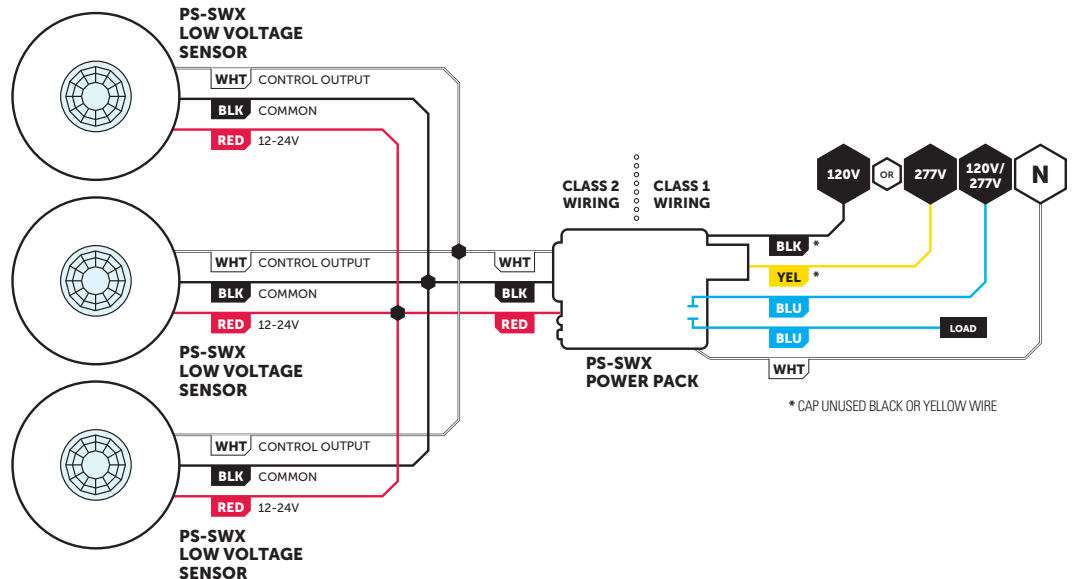

WIRING CONT.

MULTIPLE POWER PACKS WITH COMMON LINE FEEDS

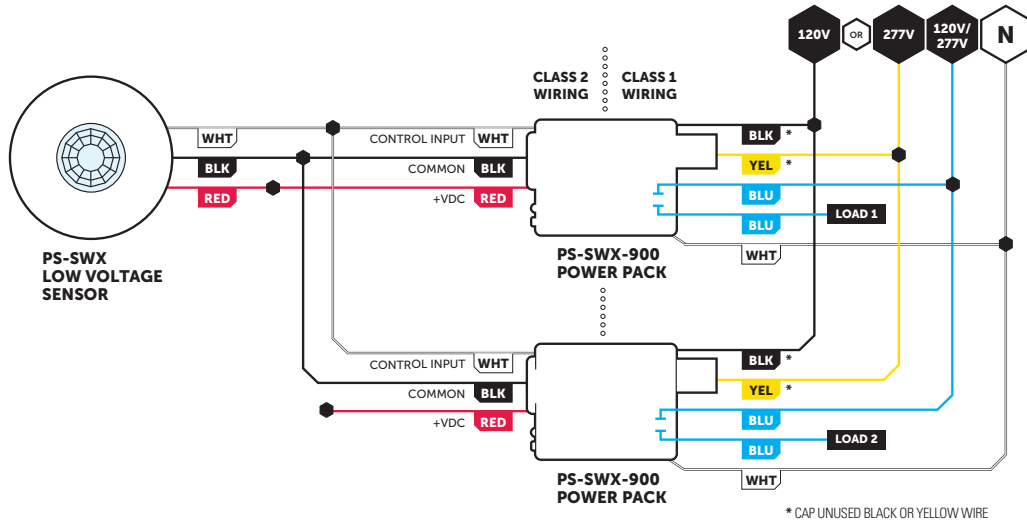

MULTIPLE POWER PACKS WITH SEPARATE LINE FEEDS

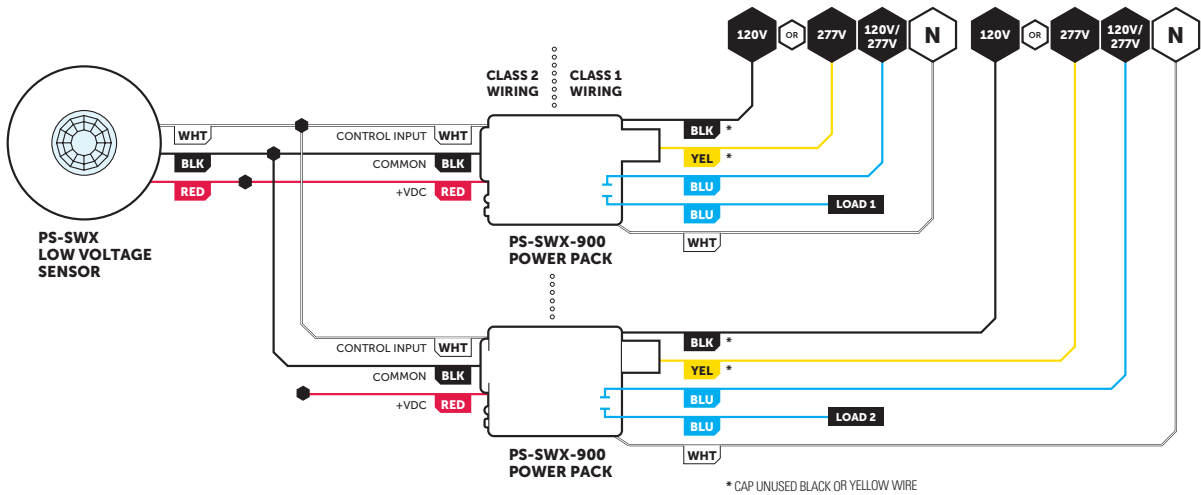

POWER PACK w/ SECONDARY RELAY PACK

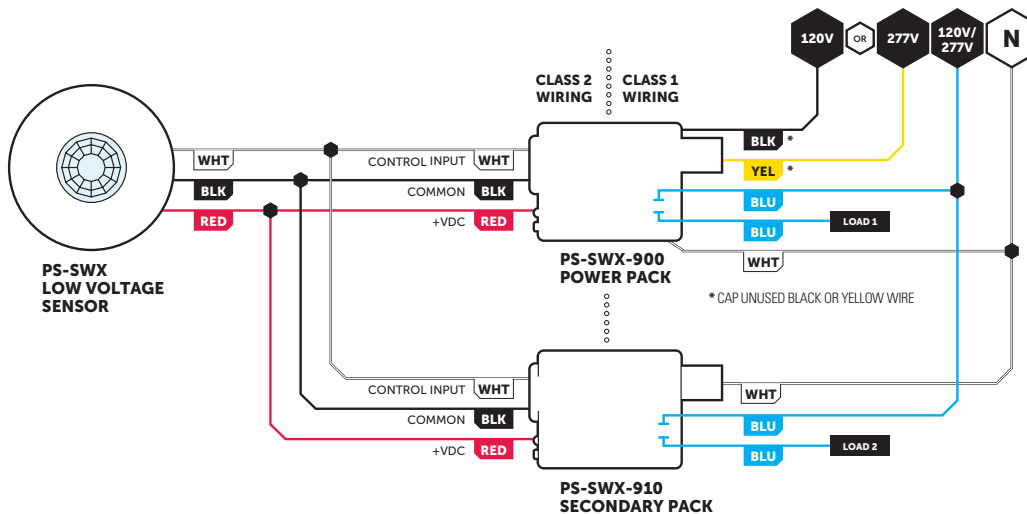

WIRING CONT.

POWER PACK CONNECTED TO SWITCH (requires -AX option)

- Some energy codes require **Manual On** (also called **Vacancy**) operation where an occupant is required to initially switch on lighting. The sensor then ensures lights are turned off once the space is unoccupied
- Interfacing momentary switches such as the PS-SWX-801-xx or PS-SWX-803-xx are recommended, however maintained switches can also be utilized
- For momentary switches, the power pack will react on the leading edge of a pulse on the brown input wire
- For maintained switches, any change of state on the brown wire that lasts longer than 0.5 seconds will be read by the power pack as one action
- If no sensor is present, tie power pack low voltage white wire to low voltage red wire

MOMENTARY SWITCH

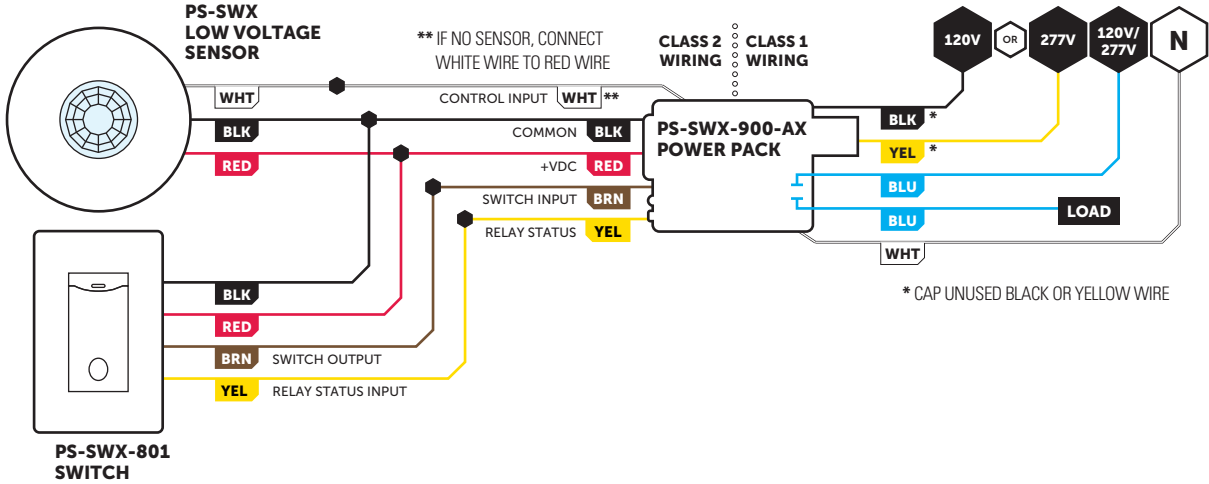

MAINTAINED SWITCH

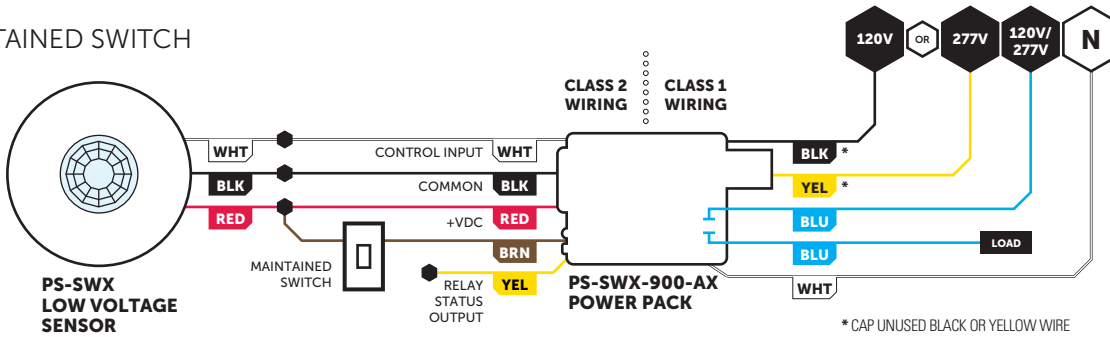

POWER PACK w/ SWITCH SIGNAL FROM EXTERNAL SYSTEM

- Typical for Hold On and Hold Off applications
- BROWN switch input can be activated by external signals +5VDC or higher (i.e. logic high)
- For hold on and hold off applications, switch input can also be configured to activate on logic low
- If no sensor is present, tie power pack low voltage white wire to low voltage red wire

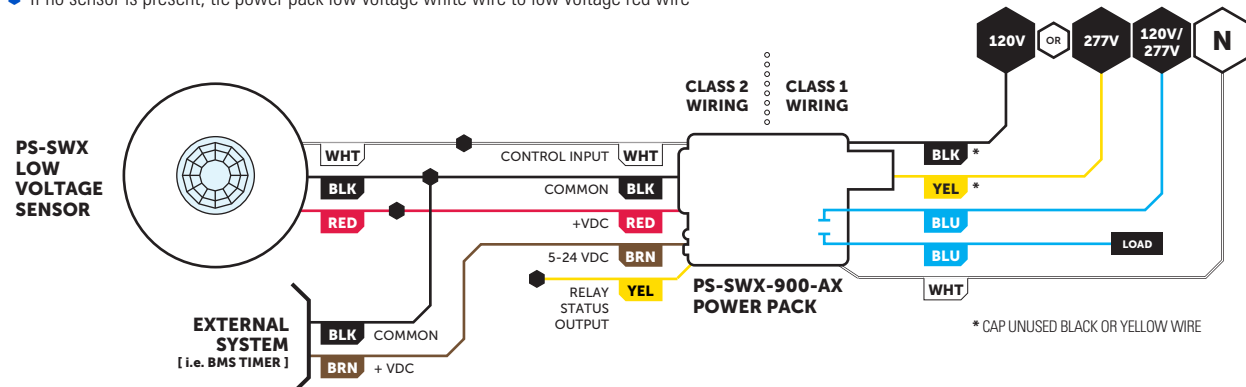

WIRING CONT.

MULTI-WAY SWITCHING (requires -AX option)

- Switching a powerpack from multiple locations (i.e., 3-way, 4-way switching) can be achieved using multiple NexLight model# **PS-SWX-801-xx** switches or a combination of one model# **PS-SWX-803-xx** dimmer and one or more model# **PS-SWX-801-xx** switches.
- Note that only one dimmer should be used per multi-way application.
- If no sensor is present, tie power pack low voltage white wire to low voltage red wire

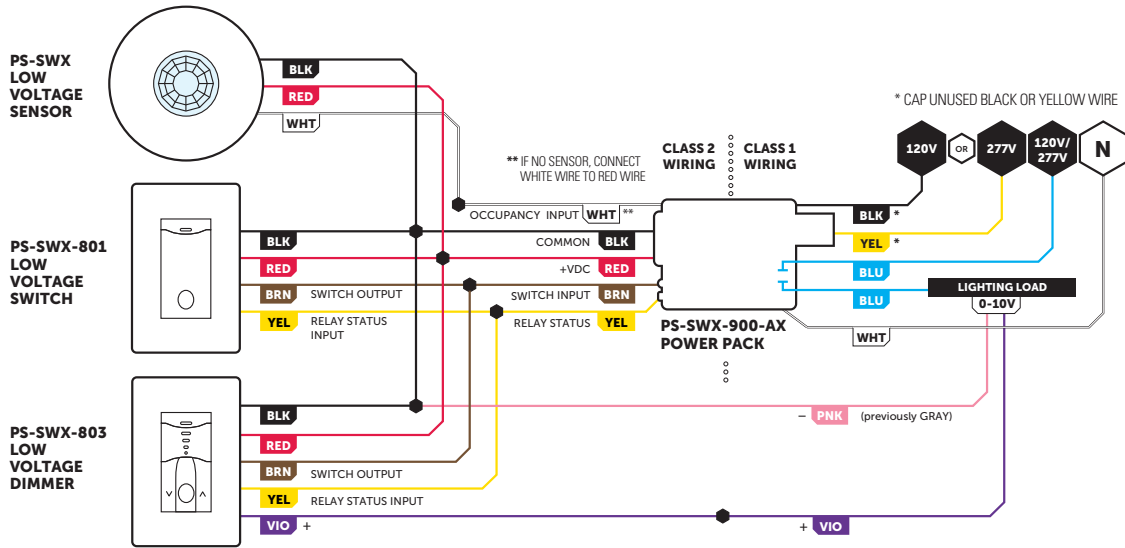

PARTIAL OFF or PARTIAL ON OPERATION (requires -AX-D2-HL options)

- For areas such as stairwells, the **PS-SWX-900-AX-D2-HL** unit can be used to achieve **Partial Off** operation where lighting is at the full bright level when occupied and dropped to the 50% level during unoccupied periods.
- **Partial On** operation is also enabled by the **PS-SWX-900-AX-D2-HL** unit. In this configuration lighting is only allowed to automatically turn on to a 50% level. Once on, an occupant may step lighting to the 100% level by pressing a wall switch. The sensor then ensures lights are turned off once the space is unoccupied.
- When in partial on mode the **PS-SWX-900-AX-D2-HL** unit will turn on connected 0-10V lighting to 50% (level is user configurable) once initially triggered from an occupancy sensor or manual switch. The unit will then step lighting up to 100% (level is user configurable) when the connected switch is pressed. Lighting will turn off if another switch press is detected or when all connected sensors go to their unoccupied state.
- Additional configurable parameters include; Turn On Dim Level, Turn Off Scheme, Fade On/Fade Off Rates, and High/Low Dimming Trim Levels.
- Using the NexLight model# **PS-SWX-801-xx** momentary switch is recommended for this application, however other manufacturers switches may also be utilized.

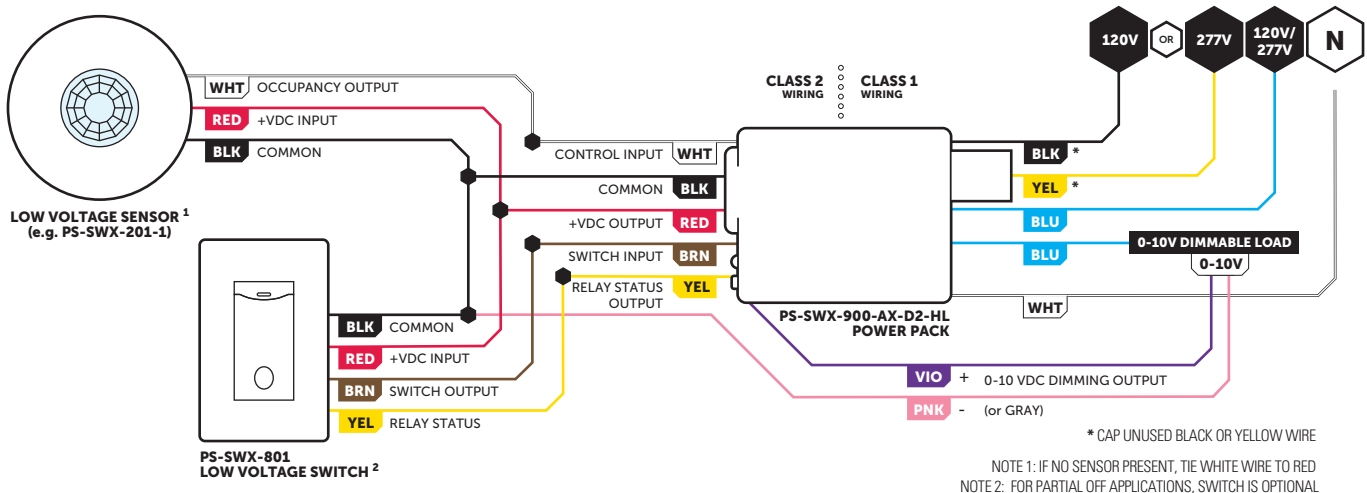

NOTE 1: IF NO SENSOR PRESENT, TIE WHITE WIRE TO RED
NOTE 2: FOR PARTIAL OFF APPLICATIONS, SWITCH IS OPTIONAL

APPLICATION NOTES

MULTI-ZONE AND BI-LEVEL SWITCHING

Rooms with multiple lighting zones or bi-level lighting often want one zone/level to switch on automatically, with the occupant able to manually switch on the additional zone/level if desired. Both zones/levels are then switched off automatically by the sensor once unoccupied. Two **PS-SWX-900-AX** power packs are wired to switches, however one unit is set to Automatic On mode while the other is set to Manual On mode. In this configuration, lighting can be switched off manually or automatically via the occupancy sensor.

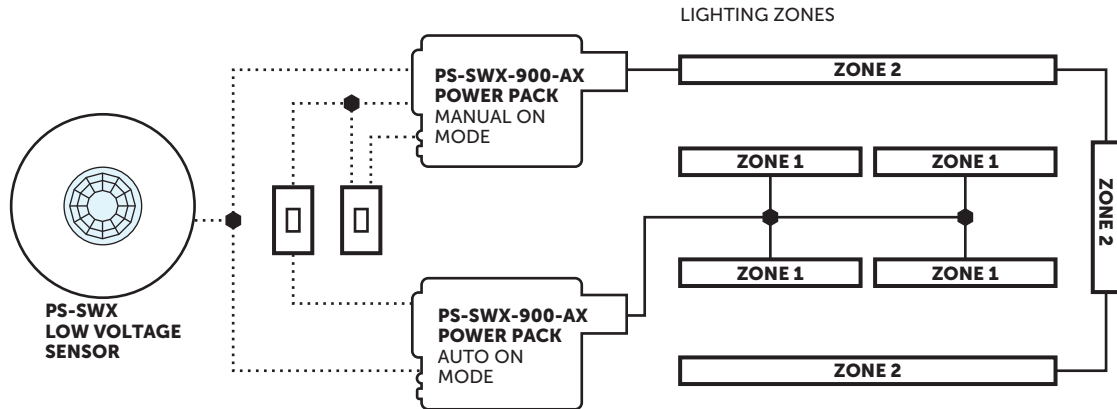

LOAD SHED / HOLD OFF APPLICATION (e.g. OPEN OFFICES)

The occupancy sensor connected to both power packs normally keeps all lights on when the space is occupied. When a load shed (override off) command is given (by BMS, utility meter, etc.), lights connected to **PS-SWX-900-AX** are held off. Remaining lights connected to **PS-SWX-900** are still controlled by the sensor.

LIGHTING

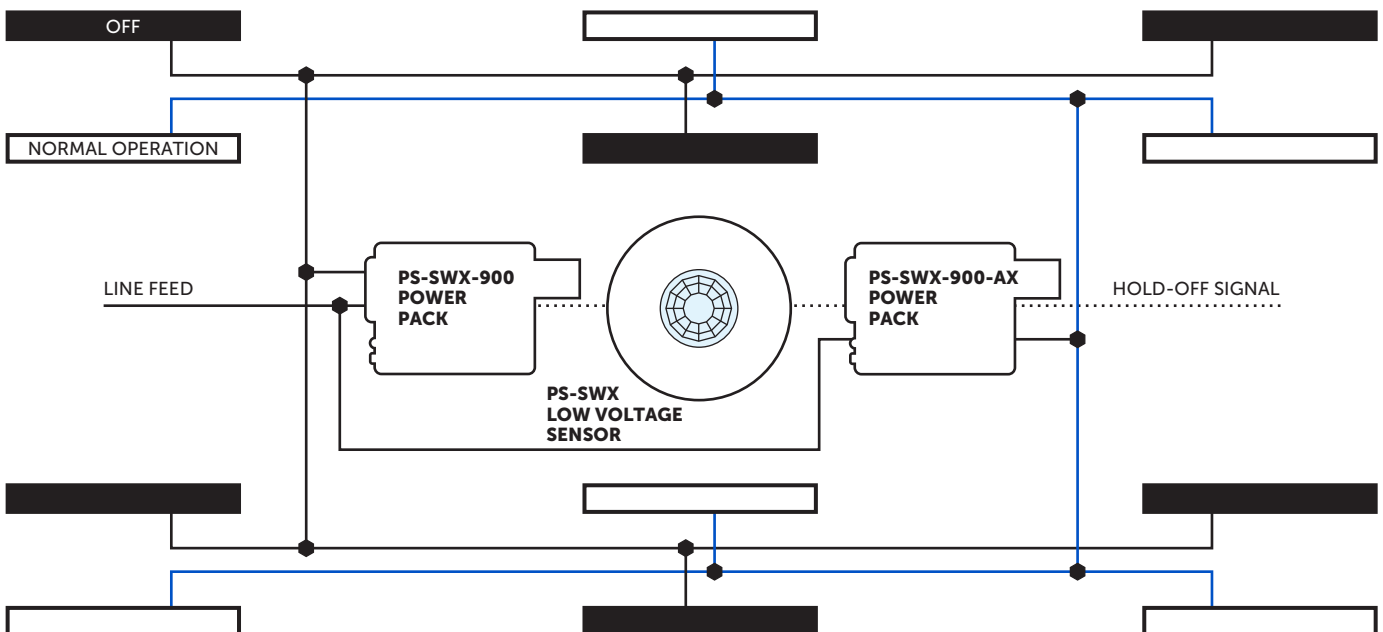

APPLICATION NOTES CONT.

SENSOR OVERRIDE / HOLD ON APPLICATION (e.g. RETAIL)

During open hours, a signal from a time clock (connected to the BROWN switch input on the **PS-SWX-900-AX**) holds lights on, regardless of occupancy. After hours, the clock's schedule releases the hold on signal enabling the occupancy sensor to take over.

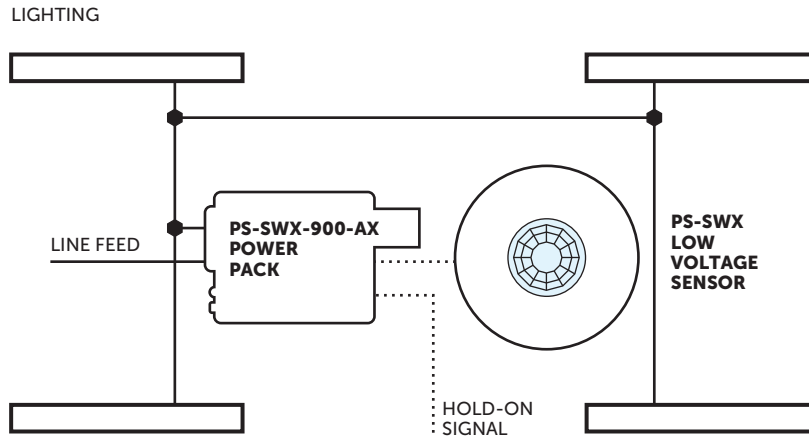

POWER PACK CAPACITY

PS-SWX-900 series power packs can supply power to several occupancy sensors and additional secondary relay packs. Following the below formula ensures adequate power will be available. Note the **PS-SWX-900's** relay has already been factored into the formula.

$$[(\# \text{ of PIR SENSORS}^*) \times 5\text{mA}] + [(\# \text{ of DUAL TECH SENSORS}) \times 10\text{mA}] + [(\# \text{ of PS-SWX-910}) \times 70\text{mA}] < [(\# \text{ of PS-SWX-900}) \times 80\text{mA}]$$

EXAMPLE COMBINATIONS

PIR SENSORS		+	DUAL TECH SENSORS		+	SECONDARY PACKS PS-SWX-910-(AR)		=	TOTAL POWER REQUIRED	<	POWER SUPPLIED BY ONE PS- SWX-900
#	POWER REQUIRED		#	POWER REQUIRED		#	POWER REQUIRED				
10	50mA	+	0	0	+	0	0	=	50mA	<	80mA
1	5mA	+	0	0	+	1	70mA	=	75mA	<	80mA
0	0	+	4	40mA	+	0	0	=	40mA	<	80mA
3	15mA	+	3	30mA	+	0	0	=	45mA	<	80mA

INSTALLATION OPTIONS

